

Board Of Harbor Commissioners

Crescent City Harbor District

5 October 2021

Regular Harbor Commission Meeting



Regular Meeting

Board of Harbor Commissioners of the Crescent City Harbor District

Brian Stone, President Wes White, Secretary

Harry Adams, Commissioner; Rick Shepherd, Commissioner; Gerhard Weber , Commissioner

AGENDA

Date: Tuesday, October 5, 2021

Time: Open Session 2:00 p.m.

Closed Session following Open Session

Place: Remote Meeting via Zoom Webinar

This meeting will be conducted pursuant to the provisions of AB 361. In an effort to protect public health and prevent the spread of COVID-19, the Board of Harbor Commissioners meeting on October 5, 2021, will be conducted via webinar and telephonically.

Link for Zoom Webinar: <https://us02web.zoom.us/j/82717545424?pwd=aExZeTRuL0VreFVEZGwweUR2TEpIdz09>

Please enter passcode: 182536

Call to Order

Roll Call

Pledge of Allegiance

Public Comment

This portion of the Agenda allows the public to comment to the Board on any issue not itemized on this Agenda, however, the Board may not take action or engage in discussion on any item that does not appear on the Agenda. Periods when public comments are allowed, Harbor Commissioners will allow attendees to submit questions and/or comments using the Zoom in-meeting chat function. The Harbor Commission asks that members of the public keep questions and comments succinct and relevant.

REGULAR SESSION

1. Consent Calendar

Consent Calendar items are considered routine and will be approved by one Motion, with no separate discussion prior to voting. The public, staff, or members of the Harbor Commission may request specific items be removed from the Consent Agenda for separate consideration or action.

- a. Approval of the Meeting Minutes of the September 21, 2021 Regular Meeting.**
- b. Approval of Warrant List from September 17, 2021 through September 29, 2021.**

2. New Business

- a. Discuss options for enhanced public safety measures on the North Jetty.**
- b. Discuss and Approve Memorial Picnic Table on north side of Harbor.**
- c. Discuss and Approve Harbor District staff attending the Tsunami Work Group Meeting in Huntington Beach on January 25, 2021**
- d. Update on the Harbor District Travelift.**
- e. Update on Harbor District Financials from Harbor District Financial Consultant Stephen Denny .**

3. Unfinished Business

- a. Solar Project Update.**
- b. Dredge Permit Update.**

4. Communications and Reports

- a. Financial Reports: Account Balances**
- b. CEO/Harbor Master Report**
- c. Harbor Commissioner Reports**

5. Adjourn to Closed Session

CLOSED SESSION

- a. CONFERENCE WITH LEGAL COUNSEL – EXISTING LITIGATION
(Government Code section 54956.9(d)(1))
Crescent City Harbor District v. Crescent Fire Protection District
Del Norte County Superior Court Case No.: CVUJ-2021-1248

6. Adjourn Closed Session

7. Report out of Closed Session

8. ADJOURNMENT

Adjournment of the Board of Harbor Commissioners will be until the next meeting scheduled for Tuesday, October 19, 2021, at 2 p.m. PDT. In accordance with AB 361, all Harbor Commission meetings will be held via Zoom Web Conferencing. Access code for public participation can be found in the meeting notice posted on the Harbor District website or on the Harbor bulletin board at 101 Citizens Dock Road.

The Crescent City Harbor District complies with the Americans with Disabilities Act. Upon request, this agenda will be made available in appropriate alternative formats to person with disabilities, as required by Section 12132 of the Americans with Disabilities Act of 1990 (42 U.S.C. §12132). Any person with a disability who requires modification in order to participate in a meeting should direct such request to (707) 464-6174 at least 48 hours before the meeting, if possible.

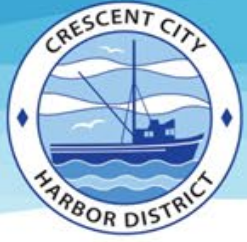

1. Consent Calendar

Consent Calendar items are considered routine and will be approved by one Motion, with no separate discussion prior to voting. The public, staff, or members of the Harbor Commission may request specific items be removed from the Consent Agenda for separate consideration or action.

- a. Approval of the Meeting Minutes of the September 21, 2021 Regular Meeting.**
- b. Approval of the Warrant List from September 17, 2021 through September 29, 2021.**

Public Comment?



Regular Meeting Minutes of the Board of Harbor Commissioners of the Crescent City Harbor District	
--	--

Harbor District Office, 101 Citizens Dock Road Crescent City, CA 95531	September 21, 2021 2:00 p.m.
---	---------------------------------

Board of Harbor Commissioners of the Crescent City Harbor District

MINUTES

Regular Meeting, Tuesday September 21, 2021 at 2:00 P.M.

CALL TO ORDER: 2:00 PM

ROLL CALL:

<i>PRESENT:</i>	<i>President</i>	BRIAN STONE
	<i>Secretary</i>	WES WHITE
	<i>Commissioner</i>	RICK SHEPHERD
	<i>Commissioner</i>	HARRY ADAMS
	<i>Commissioner</i>	GERHARD WEBER

ABSENT: NONE

QUORUM: YES

PLEDGE OF ALLEGIANCE: *led by Commissioner Adams*

PREFATORY REMARKS FROM PRESIDENT STONE: Recognizing that some members of the public had become disruptive at recent meetings, President Stone advised the public to keep comments focused on official Harbor business. While the Board welcomed thoughtful criticism, the Board had a right to limit public comments that did not maintain respect, decorum, and dignity. Furthermore, comments that were nothing more than personal attacks against members of the Board, or Harbor staff, would not be tolerated. The Board had a right to prohibit the use of profanity, yelling, or other disruptive speech or behavior. After being given a warning, further disruptive conduct could result in a member of the public being asked to leave the meeting.

PUBLIC COMMENT: The following individuals addressed the Board regarding subject matters not on the meeting agenda:

Linda Sutter expressed her approval of a lawsuit filed by the Harbor against the Crescent Fire Protection District (CFPD). The suit alleged that the Harbor never received its ballot on a proposed assessment by CFPD. Evidently, numerous other parcel owners did not receive their ballots either.

Annie Nehmer encouraged the Board to consider meeting at a time that was more convenient for the public. She suggested a morning meeting at 10AM, or an evening meeting after 5PM. On the subject of dredging, Ms. Nehmer suggested that the Board consider enlisting volunteer vessels to blow out sediment, rather than expending funds on a diver to move sediment.

Roger Gitlin requested that the Board keep the subject of dredging on the Board's agenda as a recurring item.

A woman who identified herself as Jennifer encouraged the Board to consider accessibility measures to accommodate individuals with disabilities at Board meetings. In reference to Harbor redevelopment, she asked the Board to avoid displacing existing residents. She made a distinction between displacement and eviction, noting that displacement could occur even in the absence of eviction.

Christopher Johns provided the Board with a document that enumerated legal criteria that could be used to support evictions. He advised the Board that residents would fight evictions unless the evictions were based on one or more of the criteria listed in his document.

1) CONSENT CALENDAR

(1A) Approval of the Meeting Minutes of the September 7, 2021 Regular Meeting.

(1B) Approval of the Warrant List from September 3, 2021 through September 16, 2021.

Commissioner White **moved** to approve the consent calendar. Commissioner Adams **seconded** the motion. Commissioner Weber requested a modification to the minutes of the September 7, 2021 Board meeting. The minutes had neglected to record a request made by Commissioner Weber; specifically, that a future Board meeting consider potential arrangements for RV park residents who might be impacted by Harbor redevelopment. This was Commissioner Weber's second request to have the Board consider the subject, and he expressed his displeasure at not having been afforded the opportunity to discuss the matter. Commissioner White then **amended** his motion to include the modification to the minutes requested by Commissioner Weber, after which point Commissioner Adams **seconded** the amended motion. President Stone then opened up public comment on the agenda item. Roger Gitlin requested additional information regarding items on a previous warrant list. CEO/Harbormaster Tim Petrick replied that he would provide the additional information later in the meeting, during the financial report. President Stone then moved the discussion back to the Board.

POLLED VOTE was called, **MOTION CARRIED.**

Ayes: ADAMS, SHEPHERD, WHITE, WEBER, STONE / *Nays:* NONE

Absent: NONE / *Abstain:* NONE

2) NEW BUSINESS

(2A) Introduction of New Assistant Harbormaster, Todd Garrett.

CEO/Harbormaster Tim Petrick welcomed Todd Garrett to the position of Assistant Harbormaster and discussed Mr. Garrett's background in recreation management and natural resource management. Mr. Garrett gained valuable experience in fisheries while working for the State of Montana's Department of Fish, Wildlife and Parks. The Board expressed its enthusiasm for Mr. Garrett joining the Harbor. In celebration, President Stone invited the public to enjoy refreshments at the conclusion of the meeting. President Stone then moved the discussion to the next agenda item.

3) UNFINISHED BUSINESS

(3A) Solar Project Update.

CEO/Harbormaster Tim Petrick reviewed solar production numbers for the months of February through June of 2021. Mr. Petrick reported a savings to the Harbor of approximately \$8,000 as a result of solar power generation having replaced grid provided power. This figure was based on an actual power cost of \$52,947.34, compared to a figure of \$60,889.43 that Pacific Power would have charged the Harbor in the absence of solar power generation.

Alex Lemus, CEO of Renewable Energy Capital (REC), explained that solar power generation had exceeded the Harbor's demand for electricity from February through June. Nonetheless, beginning around November, this would likely reverse, and the Harbor's electricity demand would likely exceed the supply from solar generation. This would likely occur as a result of reduced sunlight in the winter months and greater seasonal electricity demand. In particular, the expanded use of refrigerated storage containers during the winter fishing season would greatly increase electricity demand. Mr. Lemus emphasized that regardless of the amount of solar power generated, the Harbor would always pay to REC a fixed rate of 14.5 cents per kilowatt-hour of electricity consumed.

Commissioner Weber commented that the \$8,000 savings was less than he had been expecting. Mr. Lemus noted that the savings would become more substantial in the winter months. With each kilowatt-hour of electricity that was consumed, there was a proportional savings by virtue of the lower electricity rate paid to REC as compared to Pacific Power.

Commissioner Shepherd discussed the electricity demand that was attributable to cold storage units for fish. At least 3 cold storage units operated year-round. However, an additional 4 to 5 units were normally brought online in November to accommodate the crab fishing season (which normally extended into June, and sometimes into July).

President Stone asked Mr. Lemus to provide an update on when the Harbor might receive a solar licensing agreement (SLA) payment that had been promised. Mr. Lemus replied that the SLA payment continued to be delayed due to difficulties with a previous solar contractor, American Diversified Energy (ADE).

President Stone then opened up public comment on the agenda item. Linda Sutter asked for clarification on how the Harbor ensured it received accurate credit for solar generation. CEO/Harbormaster Tim Petrick then explained the Harbor's automated system of meters that recorded actual solar generation. This was compared against electricity bills to verify accurate accounting. President Stone then moved the discussion to the next agenda item.

4) COMMUNICATIONS AND REPORTS

(4A) Financial Reports: Account Balances, Profit & Loss Statements, Accounts Receivable

CEO/Harbormaster Tim Petrick reviewed financial statements with the Board. In evaluating payments made to the Harbor's technology contractor, Tech Wild, Commissioner Adams asked for clarification on the duties and responsibilities of the contractor. Mr. Petrick explained that Tech Wild provided services such as web hosting, software support, server support, and wireless Internet support.

President Stone then opened up public comment on the agenda item. Annie Nehmer commented that the Harbor appeared to be receiving interest payments on its deposits that were below what market conditions might allow. CEO/Harbormaster Tim Petrick clarified that some interest payments, such as for the Local Agency Investment Fund (LAIF), were paid quarterly, and so they might appear to be zero during intervening months. Commissioner White further explained that public entities were restricted in the types of investments that were permissible. Higher yield investments, such as certain stock portfolios, were deemed too high of a risk for public entities. Such investments were prohibited as a matter of law. President Stone then moved the discussion to the next agenda item.

(4B) CEO/Harbormaster Report

CEO/Harbormaster Tim Petrick reviewed briefing materials provided to the Board. Mr. Petrick reported that maintenance staff had been preparing for the winter season. Two new maintenance employees had been hired. One project was underway that involved removing rotten docks and replacing them with spare decommissioned materials. Other projects included repainting and striping throughout the Harbor. A meeting was held with the Harbor's insurance agent, Chris Dufour, to review the Harbor's existing insurance policy and evaluate potential changes. Also, the installation of a key fob system on the E dock restrooms had begun. Port-a-Potties had been placed along South Beach at the end of Starfish Way. Efforts were being made to obtain COVID relief funds from the State Lands Commission. Advocacy on the matter was being provided by the California Special Districts Association (CSDA), in coordination with many other California Harbormasters.

Commissioner Adams requested an update on dredging. Mr. Petrick replied that there had not been any change in status since the last meeting. Essentially, the Harbor was reliant upon the federal government to move the dredging project forward. Commissioner Adams requested that the matter be placed on every meeting agenda to allow for discussion by the Board, even when the dredging status was unchanged.

President Stone then opened up public comment on the agenda item. Annie Nehmer inquired concerning sea lion carcasses she had observed rotting on docks. Mr. Petrick replied that the Harbor was limited in the action it could take, due to restrictions imposed by the Marine Mammal Protection Act. In certain cases, such as if carcasses drifted to the shoreline, the carcasses could be towed out to sea. However, in most cases, the carcasses had to remain undisturbed, and left to decay through natural processes. President Stone then moved the discussion to the next agenda item.

(4C) Commissioner Reports.

(a) Commissioner Shepherd: no report.

(b) Commissioner Adams: reported that he had received inquiries from the public regarding the placement of locks on D Dock access points. Commissioner Adams requested an update on the matter. CEO/Harbormaster Tim Petrick replied that he had been corresponding with a contractor to have locks installed. Existing gates were problematic, and so new gates would need to be installed to better secure the facilities. Commissioner Adams then discussed the matter of restroom access at the South Beach area. He suggested it might be necessary to tear down existing bathrooms and construct an entirely new bathroom facility with a better design.

(c) Commissioner Weber: expressed frustration that two Board meetings had now passed without an opportunity to respond to concerns of RV park residents who feared evictions might result from planned Harbor redevelopment. Commissioner Weber did not agree with the decision to hold off on discussions of the matter. He was eager to share a proposal that might alleviate concerns expressed by the public.

(d) Commissioner White: reported on a meeting of the local Chamber and Visitors Bureau. He noted that tourism data demonstrated a remarkable return on investment from the Bureau. Then moving the discussion to the Tri-Agency Economic Development Authority, Commissioner White reported that a committee of the Tri-Agency had been established to focus on offshore wind power development. A new entity had been formed, the Del Norte Energy Alliance (<http://delnorteenergy.org/>). Commissioner White then reported on his observations of a section of South Beach that had become despoiled by human waste and debris. This led him to contact the County Code Enforcement Officer to see what remedies might be available. One aspect of the problem could be addressed by installing port-o-potties. Commissioner White also suggested that the Surfrider Foundation might be enlisted to provide assistance, given their history of advocacy for water quality and coastal ecosystems. Regarding the Harbor's financial matters, Commissioner White requested that the Board receive regular updates from the Harbor's newly hired financial consultant, Stephen Denny.

(e) President Stone: reported on discussions with U.S. Congressman Jared Huffman's office, and additional discussions with the office of State Senator Mike McGuire, regarding wind power development and various other Harbor related matters. With regard to wind power, President Stone also conducted discussions with the California Independent System Operator (CISO), the entity that oversees California's electricity market and power grid. President Stone then noted that he also attended a meeting of the Tri-Agency Economic Development Authority, along with Commissioner White.

MOVE TO CLOSED SESSION:

CONFERENCE WITH LEGAL COUNSEL – INITIATION OF LITIGATION
(Government Code section 54956.9(d)(4))
Number of Cases: 1

RECONVENE OPEN SESSION:

REPORT FROM CLOSED SESSION: Nothing to report.

5) ADJOURNMENT

*ADJOURNMENT TO THE BOARD OF HARBOR COMMISSIONERS NEXT REGULAR MEETING
SCHEDULED FOR TUESDAY, OCTOBER 5, 2021 AT 2 P.M., VIA ZOOM WEB CONFERENCE
AND IN-PERSON AT THE MAIN HARBOR OFFICE, LOCATED AT 101 CITIZENS DOCK ROAD.*

Approved this ____ day of _____, 2021

Brian Stone, President

Wes White, Secretary

Crescent City Harbor District Check Detail

September 17 - 29, 2021

Type	Num	Date	Name	Account	Original Amount
Check	CC PAYMENT	09/28/2021	US BANK	1040 · CCHD US BANK OPERATING 4766	-3,298.25
Bill Pmt -Check	1344	09/21/2021	ADVANCED SECURITY SYSTEMS CC	1047 · BAYSIDE- RV PARK-1766	-106.50
Bill Pmt -Check	1345	09/21/2021	CCWATER	1047 · BAYSIDE- RV PARK-1766	-2,261.33
Bill Pmt -Check	1346	09/21/2021	MENDES SUPPLY CO	1047 · BAYSIDE- RV PARK-1766	-229.20
Bill Pmt -Check	1348	09/21/2021	SUBURBAN PROPANE	1047 · BAYSIDE- RV PARK-1766	-607.51
Check	1349	09/29/2021	KENNETH BRUCE DWELLEY	1047 · BAYSIDE- RV PARK-1766	-4,190.50
Check	1350	09/29/2021	ROBERT J. FRAZIER	1047 · BAYSIDE- RV PARK-1766	-4,190.50
Bill Pmt -Check	1351	09/29/2021	RECOLOGY DN	1047 · BAYSIDE- RV PARK-1766	-2,299.28
Bill Pmt -Check	1352	09/29/2021	SUBURBAN PROPANE	1047 · BAYSIDE- RV PARK-1766	-449.05
Check	2059	09/21/2021	DANIEL CROZIER	1045 · REDWOOD HARBOR VILLAGE 0707	-225.00
Bill Pmt -Check	2060	09/21/2021	CCWATER	1045 · REDWOOD HARBOR VILLAGE 0707	-2,002.51
Bill Pmt -Check	2061	09/21/2021	MENDES SUPPLY CO	1045 · REDWOOD HARBOR VILLAGE 0707	-229.20
Bill Pmt -Check	2062	09/21/2021	PACIFIC POWER	1045 · REDWOOD HARBOR VILLAGE 0707	-3,916.90
Bill Pmt -Check	2063	09/21/2021	SUBURBAN PROPANE	1045 · REDWOOD HARBOR VILLAGE 0707	-271.81
Check	2064	09/21/2021	CARRIE COOK	1045 · REDWOOD HARBOR VILLAGE 0707	-325.00
Check	2065	09/21/2021	ROSENA CASADOS	1045 · REDWOOD HARBOR VILLAGE 0707	-225.00
Bill Pmt -Check	2066	09/29/2021	RECOLOGY DN	1045 · REDWOOD HARBOR VILLAGE 0707	-2,583.48

Crescent City Harbor District
Check Detail
September 17 - 29, 2021

Bill Pmt -Check	2067	09/29/2021	SUBURBAN PROPANE	1045 · REDWOOD HARBOR VILLAGE 0707	-195.24
Bill Pmt -Check	6089	09/21/2021	ACCONTEMPS	1040 · CCHD US BANK OPERATING 4766	-4,264.40
Bill Pmt -Check	6090	09/21/2021	ADVANCED SECURITY SYSTEMS CC	1040 · CCHD US BANK OPERATING 4766	-162.75
Bill Pmt -Check	6091	09/21/2021	AIRMED CARE NETWORK/CAL ORE	1040 · CCHD US BANK OPERATING 4766	-990.00
Bill Pmt -Check	6092	09/21/2021	C RENNER PETROLEUM INC	1040 · CCHD US BANK OPERATING 4766	-514.55
Bill Pmt -Check	6093	09/21/2021	CCWATER	1040 · CCHD US BANK OPERATING 4766	-2,540.99
Bill Pmt -Check	6094	09/21/2021	CRESCENT ELECTRIC	1040 · CCHD US BANK OPERATING 4766	-19,819.05
Bill Pmt -Check	6095	09/21/2021	ENGLUND MARINE	1040 · CCHD US BANK OPERATING 4766	-132.14
Bill Pmt -Check	6096	09/21/2021	DN OFFICE	1040 · CCHD US BANK OPERATING 4766	-180.97
Bill Pmt -Check	6097	09/21/2021	EUREKA OXYGEN	1040 · CCHD US BANK OPERATING 4766	-148.54
Bill Pmt -Check	6098	09/21/2021	HARSHWAL & COMPANY LLP	1040 · CCHD US BANK OPERATING 4766	-10,000.00
Bill Pmt -Check	6099	09/21/2021	HUMBOLDT STATE UNIVERSITY	1040 · CCHD US BANK OPERATING 4766	-2,136.17
Bill Pmt -Check	6100	09/21/2021	MENDES SUPPLY CO	1040 · CCHD US BANK OPERATING 4766	-361.83
Bill Pmt -Check	6101	09/21/2021	PIECE BY PIECE POTTERY	1040 · CCHD US BANK OPERATING 4766	-500.00
Bill Pmt -Check	6102	09/21/2021	PORTER SCOTT	1040 · CCHD US BANK OPERATING 4766	-2,655.54
Bill Pmt -Check	6103	09/21/2021	PROGRESSIVE INSURANCE	1040 · CCHD US BANK OPERATING 4766	-769.08
Bill Pmt -Check	6104	09/21/2021	R.A. KIRKLAND INC.	1040 · CCHD US BANK OPERATING 4766	-5,833.33

Crescent City Harbor District
Check Detail
September 17 - 29, 2021

Bill Pmt -Check	6105	09/21/2021	REDWOOD LEAVITT INS AGENCY	1040 · CCHD US BANK OPERATING 4766	-19,800.00
Bill Pmt -Check	6106	09/21/2021	STREAMLINE	1040 · CCHD US BANK OPERATING 4766	-200.00
Bill Pmt -Check	6107	09/21/2021	TECH-WILD	1040 · CCHD US BANK OPERATING 4766	-1,285.00
Bill Pmt -Check	6108	09/21/2021	THERMO FLUIDS INC	1040 · CCHD US BANK OPERATING 4766	-584.98
Bill Pmt -Check	6109	09/21/2021	WANNER FAMILY CHIROPRACTIC	1040 · CCHD US BANK OPERATING 4766	-120.00
Bill Pmt -Check	6110	09/21/2021	XEROX	1040 · CCHD US BANK OPERATING 4766	-389.62
Check	6111	09/29/2021	CARPENTERS LOCAL 751	1040 · CCHD US BANK OPERATING 4766	-60.00
Bill Pmt -Check	6112	09/29/2021	ACCOUNTEMPS	1040 · CCHD US BANK OPERATING 4766	-4,266.00
Bill Pmt -Check	6113	09/29/2021	ARAMARK INC	1040 · CCHD US BANK OPERATING 4766	-159.98
Bill Pmt -Check	6114	09/29/2021	C RENNER PETROLEUM INC	1040 · CCHD US BANK OPERATING 4766	-551.56
Bill Pmt -Check	6115	09/29/2021	CRESCENT ACE HARDWARE	1040 · CCHD US BANK OPERATING 4766	-626.39
Bill Pmt -Check	6116	09/29/2021	MENDES SUPPLY CO	1040 · CCHD US BANK OPERATING 4766	-226.25
Bill Pmt -Check	6117	09/29/2021	O'REILLY AUTO PARTS	1040 · CCHD US BANK OPERATING 4766	-65.09
Bill Pmt -Check	6119	09/29/2021	RECOLOGY DN	1040 · CCHD US BANK OPERATING 4766	-3,771.54
Bill Pmt -Check	6120	09/29/2021	THERMO FLUIDS INC	1040 · CCHD US BANK OPERATING 4766	-584.98
Bill Pmt -Check	6121	09/29/2021	TECH-WILD	1040 · CCHD US BANK OPERATING 4766	-1,125.00
				TOTAL	-112,431.99



2. New Business

- a. Discuss options for enhanced public safety measures on the north Jetty.**

Public Comment?

Danger



**Deadly Waves
at Any Time**



**Jetty Unsafe
for Walking**



Danger
Deadly Waves
at Any Time
Jetty Unsafe
for Walking





2. New Business

- b. Discuss and Approve Memorial Picnic Table on north side of Harbor.**

Public Comment?

September 24, 2021

Crescent City Harbor District
101 Citizens Dock Rd
Crescent City, CA 95531

Attention: Crescent City Harbor Board of Directors

Reg: Permission to place Memorial Table at Crescent City Harbor and hold dedication picnic

Dear Board Members,

My father, Larry Elliott, is a long time renter of a pleasure slip at the Crescent City Harbor where he has moored his boat the *Ali Lynn*. My father loved the harbor, loved to fish and loved the fishing lifestyle. Most recently, dad lived aboard the *Ali Lynn* and enjoyed his life immensely, befriending most of the commercial and pleasure fisherman as well as fishing whenever he could.

On September 10th, my father succumbed to the Covid 19 pandemic and passed away. As much as we are devastated, my siblings and I could think of no better way to memorialize our father than by placing a memorial table that overlooks the harbor in his honor. Dad loved and enjoyed the beauty of Crescent City; we have spent many afternoons enjoying the benches already there in the harbor (giving us the idea). We know that dad would love to think of us, and all of his friends doing the same thing, remembering him at the same time. We intend to keep his *Ali Lynn* at the harbor.

Our family is asking that you put the following items on your agenda for approval:

1. Allow us to place a concrete table in the harbor. (see attached for photos and possible placement)
2. Give us permission, and a permit, to dedicate the requested table by having a private picnic for friends and family in the parking lot of the harbor near the table.

We greatly appreciate your consideration. Please contact me with questions or suggestions. I look forward to hearing from you.

Amanda Elliott-Ester
530 227-9104
ajelliott1@hotmail.com

Details of Requested Dedication Picnic:

Date: November 23, 2021

Time: 2-5 pm

Attendees: 50 to 60 family & friends

- The idea is to rent a tent, tables and chairs.
- We will have a pot-luck style with most of the food prepared at other places.
- We want to use our own personal portable gas grills to cook fish.
- We will use a small, wireless speaker to play music.

Due to my fathers passing of Covid, we want to ensure a celebration outside with plenty of distance and fresh air.

This event should in no way impede the normal operation of harbor activities.

Proposed Table:

(with a small brass memorial plaque in the center)



92" Round, color to match other benches in harbor, sealed concrete
From: Outdoor Creations Inc. in Anderson, Ca.

Proposed Location:

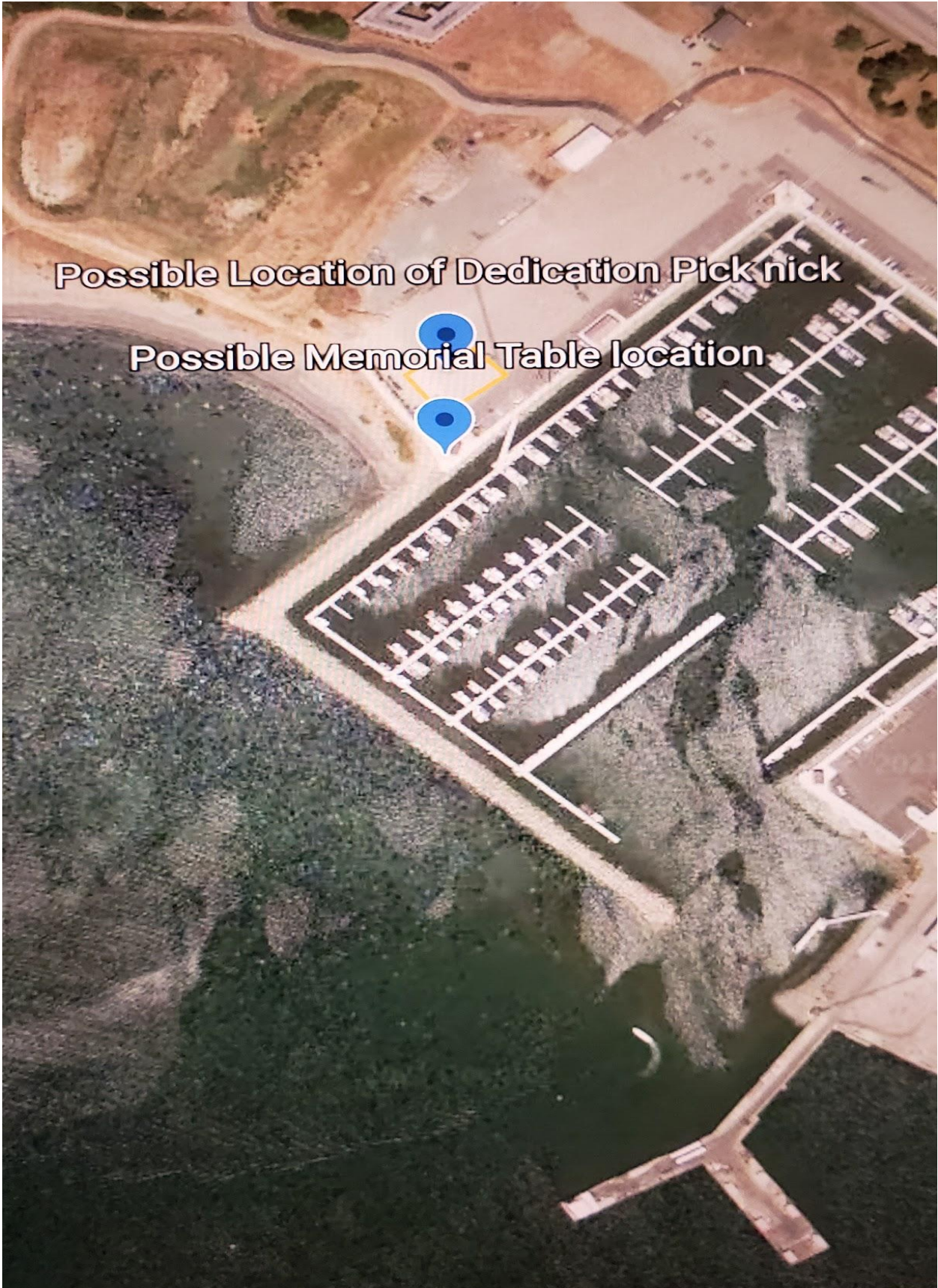

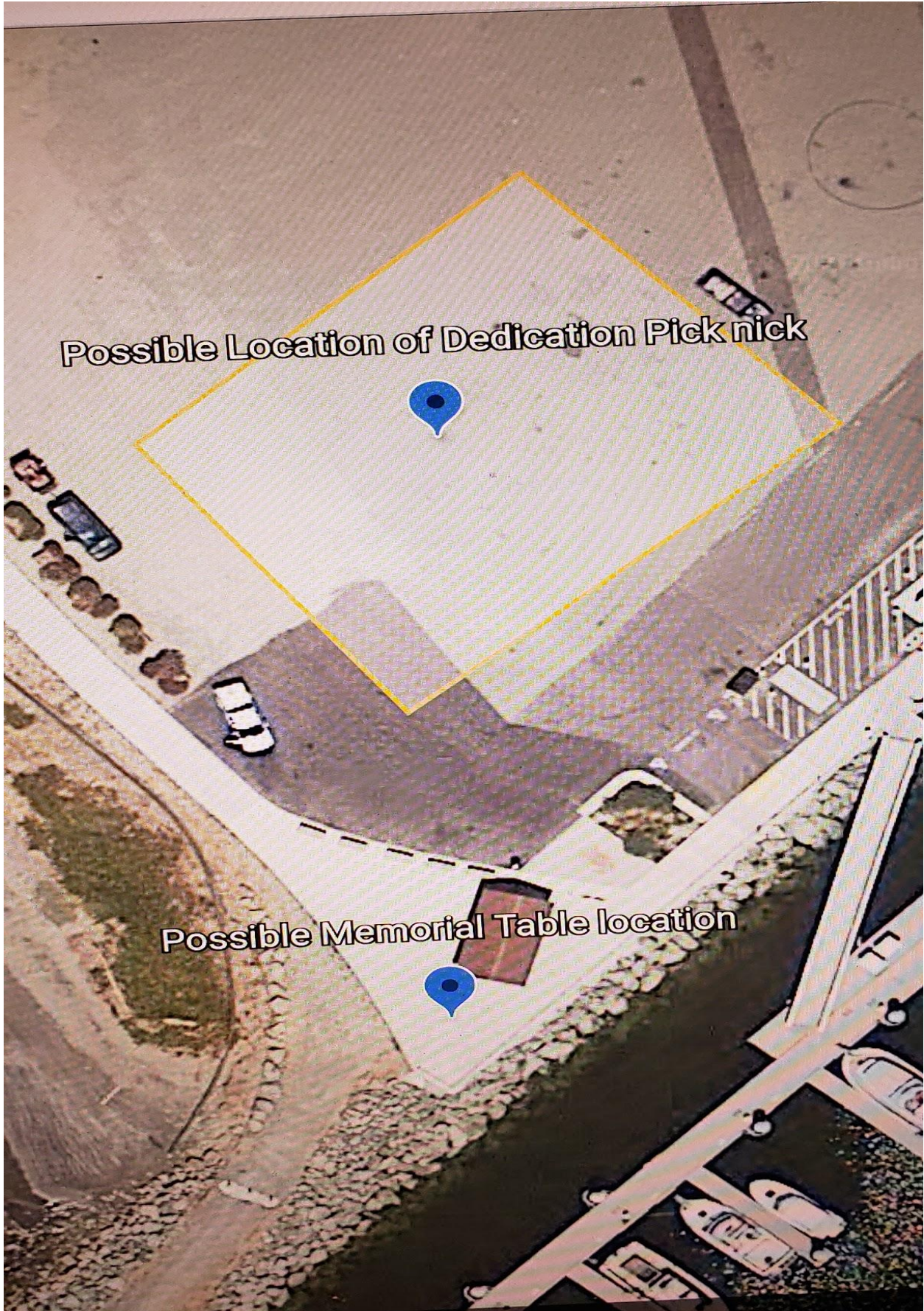



2. New Business

- c. **Discuss and Approve Harbor District staff attending the Tsunami Work Group Meeting in Huntington Beach on January 25, 2021.**

Public Comment?

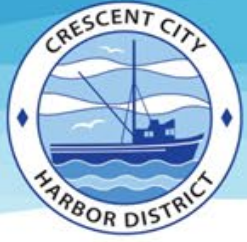

2. New Business

d. Update on the Harbor District Travelift.

Public Comment?

50 BFMII

MOBILE BOAT HOIST
50 Metric Ton Capacity - Tier 4

MARINE  TRAVELIFT®

STANDARD SPECIFICATIONS

	US Measure	Metric
General Information		
Rated lifting capacity	110,000 lbs	50,000 kg
Shipping weight	41,200 lbs	18,690 kg
*Machine shipped disassembled.		
Inside clear height	20'0"	6.10 m
Inside clear width	20'0"	6.10 m
Engine		
Engine make/model	Deutz Diesel 2.9L - Tier 4	
Horsepower	72 HP @ 2200 RPM / 54 kW	
Cooling	Liquid	
Service Capacities		
Oil tank capacity	30 Gal	114 L
Fuel tank capacity	30 Gal	114 L
Hoist System		
Hoists	(4) Independent Hydraulic Controls	
Hoisting speed (standard)	10 ft/min	3.05 m/min
Hoisting speed (low/high) (optional)	10/24 ft/min	3.05/7.32 m/min
Number of parts of lines	16	
Wire rope	1/2" (12.7 mm), Compacted 8 x 26, Galvanized IWRC	
Depth below grade (standard)	5'0"	1.52 m
Depth below grade (optional)	20'0"	6.10 m
Slings		
Minimum block spacing	8'0"	2.44 m
Maximum block spacing	22'0"	6.71 m
Slings	(2) Nylon 2-ply, Quick disconnect pin	
Protection	Keel pads and Chine pads	
Sling dimension	12" x 30'	0.30 m x 9.14 m
Drive System		
Drive type	Hydrostatic, closed loop	
Travel speed (low/high) (standard)	80/170 ft/min	24.38/51.82 m/min
Gradeability (standard)	4%	
Increased Gradeability (optional)	6.5%	
*Increased gradeability reduces travel speeds.		
**Gradeability shown for concrete or asphalt surfaces. For other surfaces, deduct as follows: Hard packed ground or gravel...2%; Loose gravel...2 to 7%; Mud...2 to 13%; Soft sand...4 to 13%.		
Tires		
Tire type	(4) Lug 16.00-25	
Tire pressure	140 PSI	9.7 Bars
Steering Type		
2-WS outside turning radius	32'8"	9.96 m
Exterior Paint		
Color	PPG Protective Coating	
Primer	Blue & Grey	
Paint	Zinc Rich Epoxy	
	Engineered Siloxane	

Model 50 BFMII at MarineMax, Florida, USA



(Machine may be shown with options)

STANDARD EQUIPMENT

- Greaseless Pivot Trunnion
- Remote Diagnostics
- Intelligent Electronic Load Indication
- Hydraulic Oil Temperature Monitor
- Hydraulic Pump Pressure Monitor
- Cab Control Direct to Valve
- Industrial Tires
- Formed Steel Structure
- Slew Bearing for Steer Wheels
- Bolting Flange in Top Beam
- Stainless Steel Tubing
- O-Ring Face Seal Hydraulic Fittings
- Cordura Hose Covers
- Parallel Groove Drums
- Chine & Keel Pads
- Greaseless Hydraulic Sling Adjustment
- 2 Speed Drive
- Mechanically Synchronized Hoists

OPTIONS

- Customizable in Height and Width
- Wireless Remote Control with LCD Display
- All Wheel Electronic Steering (Includes Increased Gradeability)
- AVT Fuel Saver (Wireless Remote Control Required)
- Sailboat Top Beam Extension
- Yanmar Engine
- Enclosed Cab with Heater, Defroster Fan, & Wiper
- LED Work & Drive Lights
- Sound Suppression Kits
- 2 Speed Hoist
- Larger Tires Reduced Ground Pressure
- Tire Pressure Monitor
- Jib Cranes
- Change in Block Drop (Below Pier Level)
- Cold Start Kit
- CE Compliance

* Height & width can be modified to fit customer specifications.

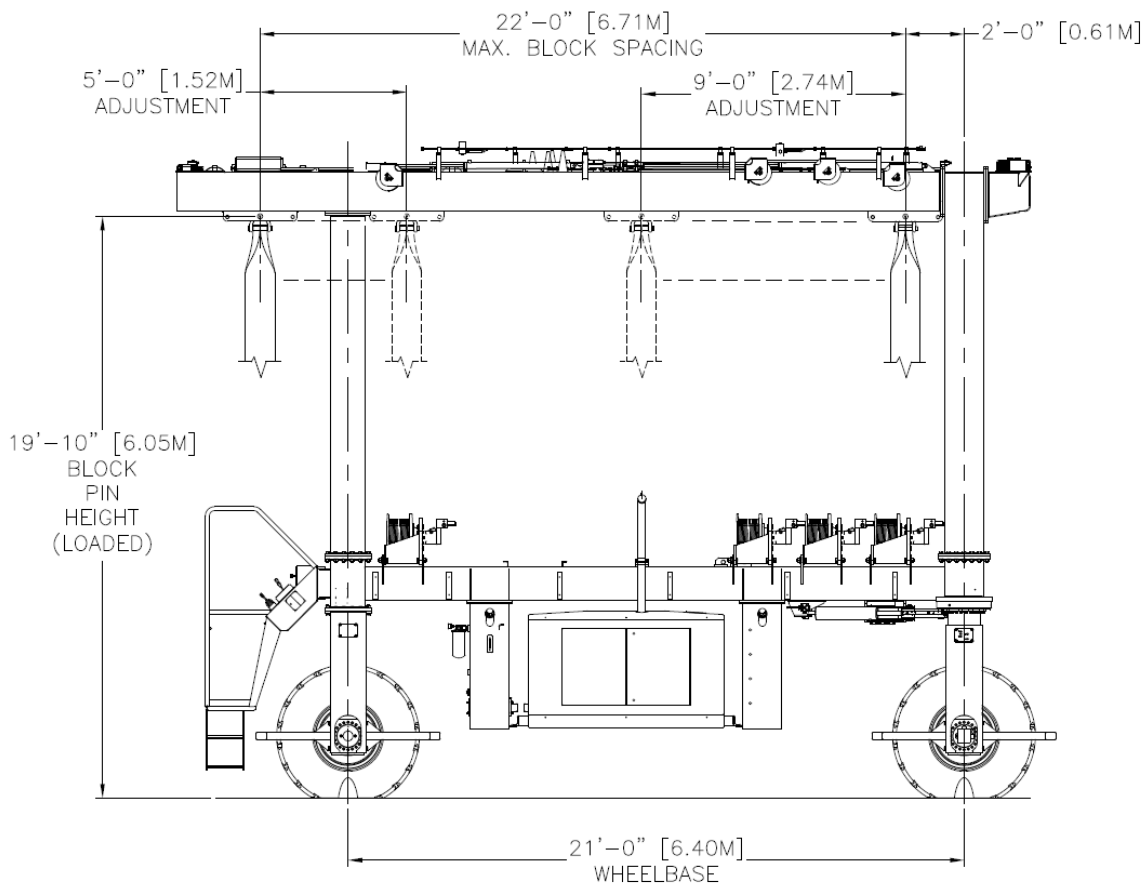
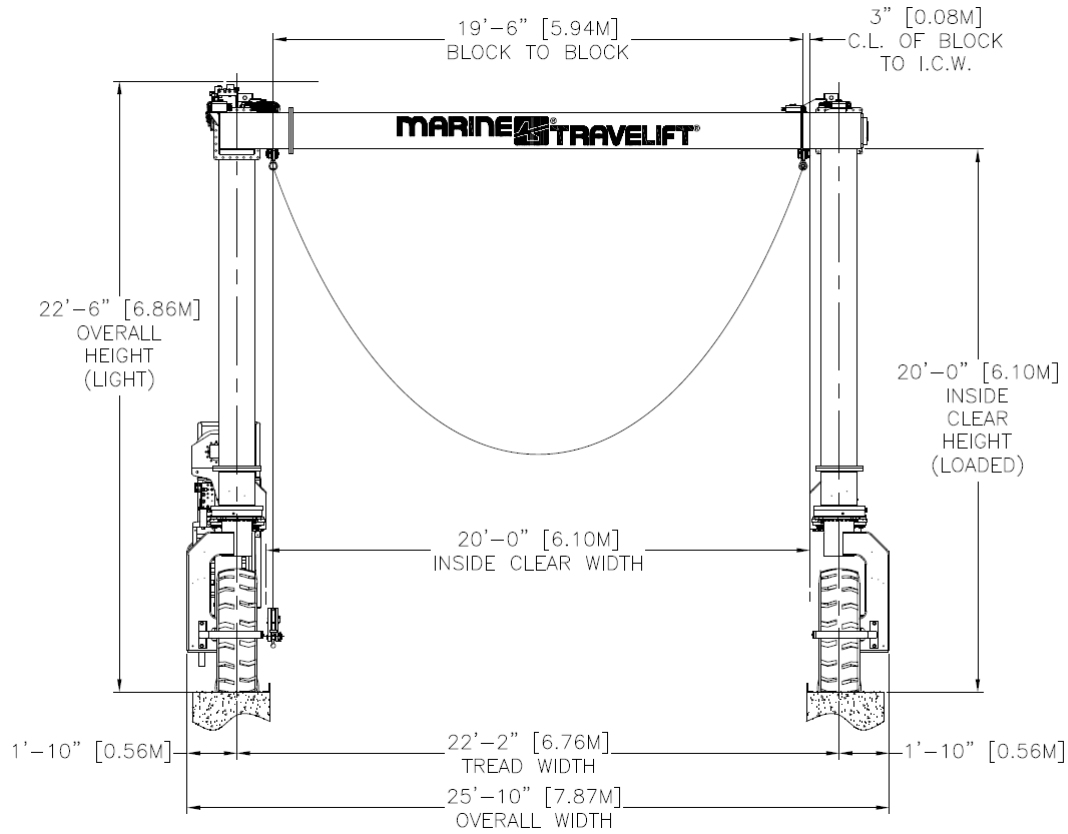

Sales Offer for: Tim Petrick
 Crescent City Harbor District
 Crescent City, CA 95531
 USA
 707 464 6174
 tpetrick@ccharbor.com

Document # 81921-359628
 Print Date 19-Aug-21
 Last Update: 19-Aug-21
 Offer Expires: 9-Sep-21

PRICES ARE IN **USD**

This is a detail sales proposal for the equipment and options listed below. This proposal must include the technical specifications and either the preliminary general arrangement or the final separate detailed general arrangement file identified below. In the case of both, the separate general arrangement file referenced supercedes. Contract agreed, if all pages signed and down payment received before expiry date.

<i>Marine Travelift</i>	<i>50BFMII</i>	<i>Boat Hoist</i>
Nominal Rated capacity	110000 Lbs or	50000 kg
Inside Clear Height (loaded):	20'0" or	6.1m
Machine inside clear width	20'0" or	6.1m
Negative lift of hoist block	-15'0" or	-4.6m
Maximum hoist spacing	22'0" or	6.7m
ENGINE and POWER PLANT	Deutz 2.9L 72HP StageV	

Cost adjustment in effect. The cost adjustment is based on the short term rapid change in price of steel, components and tires. The cost adjustment is a pass through from the factory to the customer.

Note gradeability for full capacity, grade is measured by wheel height difference front to rear divided by wheelbase minus 1% for rolling resistance on perfect surface.

Note 3

This offer includes the above machine with following features and options:

QTY	DESCRIPTION	PRICE
1	Mobile Boat Hoist	\$ 323,300
1	Designed for hot climates	\$ -
10	Hoist negative lift (extra cable)	\$ 1,650
1	2nd Hoist speed	\$ 3,885
1	Noise suppression level 1	\$ 1,045
1	Deutz 2.9L 72HP StageV	\$ 1,400
1	Wireless Radio remote control for all functions	\$ 21,500
1	Cost variation adjustment	\$ 33,170
	MACHINE PRICE BEFORE SHIPPING	\$ 385,950
	(Including all selected options, dimensions and special options)	
1	Customer name on upper side beams	\$ -
1	US Supervisor for assembly in North America (Canada and USA) including travel and lodging	\$ 8,000
	SERVICES	\$ 8,000

1	Truck loading	\$	1,200
1	Truck Conestoga	\$	11,190
Machine dismantled and loaded on truck for US delivery		\$	12,390

Point of Loading	Wisconsin USA factory
Point of delivery	name of port, door address, factory address
Point of transfer of ownership	Wisconsin USA factory
Freight incoterm / US terms	FOB + Freight name of port, door address, factory address
Estimated freight time	3 days, estimated, from loading

TOTAL **\$ 406,340**

Validity of offer	September 9, 2021
Estimated order date	August 29, 2021
Machine lead time	150 Days
Estimated completion date	January 26, 2022

TERMS

35%	Down payment	Wire Transfer	8/29/2021	\$	142,219
65%	Balance prior to shipping	Wire Transfer	1/5/2022	\$	264,121

FINANCE

Option 1 - Eligible for section 179	\$0 down / \$1 payment to own at term.			
Lease length	Rate	Monthly payment	Total of Payments	
84 month term	-0.014	(\$5,696)	(\$478,428)	
72 month term	-0.015	(\$6,265)	(\$451,089)	
60 month term	-0.018	(\$7,392)	(\$443,523)	
48 month term	-0.022	(\$9,084)	(\$436,040)	
36 month term	-0.029	(\$11,907)	(\$428,639)	

Option 2 - NOT eligible for section 179	\$0 down / Buyout at term.			
Lease length	Rate	Monthly payment	Buyout	Total of Payments
84 month term	-0.010	(\$4,265)	35%	(\$358,265)
72 month term	-0.010	(\$4,233)	40%	(\$304,785)
60 month term	-0.011	(\$4,599)	45%	(\$275,936)
48 month term	-0.013	(\$5,135)	50%	(\$246,463)
36 month term	-0.015	(\$6,010)	55%	(\$216,353)

Based on approval from lender/leasing. Rate may vary upon approval. Numbers provided for indication only, buyer to lease directly with leasing company.

I certify that this offer will be honored upon reception of the above down payment within the validity date above, and copy of this offer countersigned by the buyer along with a signed copy of the Superceding General Arrangement drawing listed above.

Scott Alger

Sales Director
Marine Travelift Inc.

salger@marinetraavelift.com

www.marinetraavelift.com

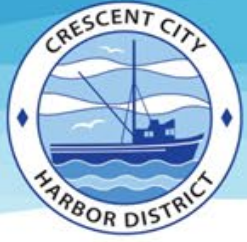

2. New Business

- e. Update on Harbor District Financials from Harbor District Financial Consultant Stephen Denny.**

Public Comment?

Crescent City Harbor District Income Sources

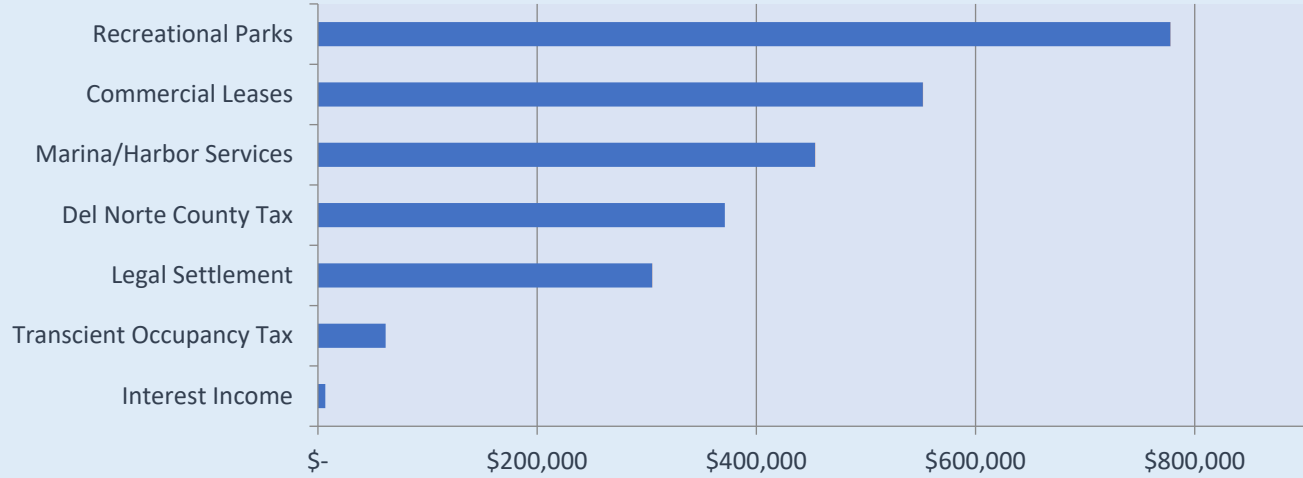

Crescent City Harbor District Income Sources

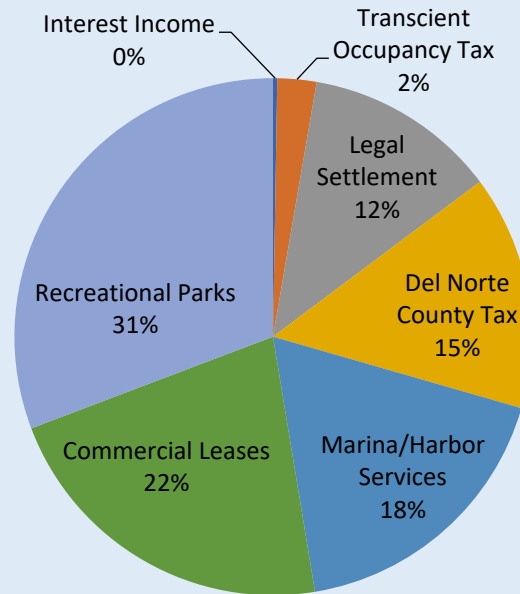

Crescent City Harbor District Income Sources

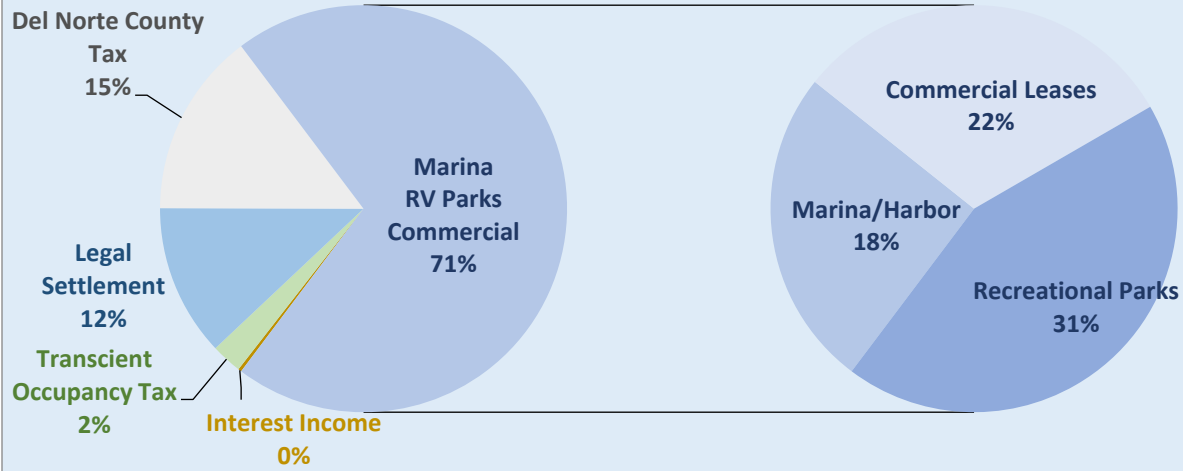

Interest Income	\$ 6,664.58	0.26%
Transient Occupancy Tax	\$ 61,774.45	2.44%
Legal Settlement	\$ 305,000.00	12.06%
Del Norte County Tax	\$ 371,322.97	14.69%
Marina/Harbor Services	\$ 453,625.56	17.94%
Commercial Leases	\$ 551,937.96	21.83%
Recreational Parks	\$ 777,878.18	30.77%
Total	\$ 2,528,203.70	100.00%

Source	\$	%
Recreational Parks	777,878.18	30.77%
Commercial Leases	551,937.96	21.83%
Marina/Harbor Services	453,625.56	17.94%
Del Norte County Tax	371,322.97	14.69%
Legal Settlement	305,000.00	12.06%
Transient Occupancy Tax	61,774.45	2.44%
Interest Income	6,664.58	0.26%
Total	\$ 2,528,203.70	100.00%



3. Unfinished Business

a. Solar Project Update

Public Comment?

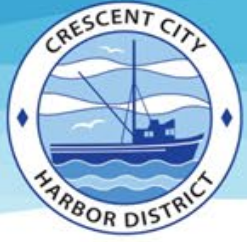

3. Unfinished Business

b. Dredge Permit Update

Public Comment?



4. Communication and Reports

a. Financial Reports: Account Balances

Public Comment?

BANK BALANCES AS OF 9.16.21		BANK BALANCES AS OF 9.29.21		DIFFERENCE
CCHD OPERATING	\$102,402.56	CCHD OPERATING	\$58,446.37	-\$43,956.19
CCHD SAVINGS	\$30,021.29	CCHD SAVINGS	\$30,021.29	\$0.00
REDWOOD HARBOR	\$119,310.90	REDWOOD HARBOR	\$80,402.66	-\$38,908.24
BAYSIDE RV PARK	\$60,417.66	BAYSIDE RV PARK	\$48,033.43	-\$12,384.23
LAIF ACCOUNT	\$1,394,957.09	LAIF ACCOUNT	\$1,394,957.09	\$0.00
TOTALS	\$1,707,109.50	TOTALS	\$1,611,860.84	-\$95,248.66



4. Communications and Reports

b. CEO/Harbormaster Report

As discussed earlier in the meeting there was an unfortunate loss of life on 9/28 when a young man was washed off of the North Jetty and drowned. The Sheriff and Fish and Wildlife responded and based the operation from the launch ramp. They launched their boats from the floating docks by the old Coast Guard dock and returned the young man to the launch ramp where medical personnel were waiting. Despite the sad outcome I want to thank the Sheriff, Fish and Wildlife, and the Fire fighters who responded.

We have hired a new person for the front desk position which has been open. Ivonne is working hard to learn the ins and outs of working in a harbor setting with the many personalities we work with on a daily basis. Welcome to the team Ivonne, we're happy to have you here.

We've been proactively contacting boat owners whose vessels don't seem to be prepared for the winter. A reminder to boat owners, It is much cheaper to check your bilge pumps and mooring lines now than to have divers attempt to refloat your boats in a storm. Please make sure that your battery chargers are marine grade and are functioning properly, your mooring lines are in good shape and snug to the dock, and check your vessel frequently during the rainy season.

Continued on next slide...

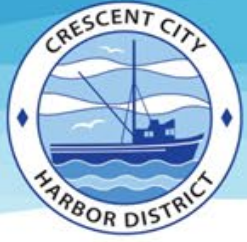

4. Communications and Reports

b. CEO/Harbormaster Report

I am working with the company that we purchased prior restroom replacements from to acquire pricing on full restroom replacements for both the B dock restroom and the South Beach restroom for commission approval.

CCHD in partnership with Drea from the Food Council has made it through the first phase of grant approval for an up to \$300,000 grant to help support small commercial fishermen. We will begin working together to complete the next phase for submittal in November.

We have also identified federal and state infrastructure grants that could be used for many of the high dollar projects that will need to be completed in the harbor area in the next 5 years. We are starting pulling together application materials for the applicable grants.

Financial Consultant, Stephen Denny, has done some great work over the last couple weeks pulling together the amount of money spent over the last 18 months due to Covid combined with the lost revenues from that time period. There are multiple different pools of money set aside by both the federal government and the State of California for Covid relief in ports and harbors. After review, I believe that we qualify for some of these programs and we are working on our applications to recover some of those revenues.

Public Comment?



4. Communications and Reports

c. Harbor Commissioner Reports

Pursuant to the Brown Act, this item allows the Commissioners to briefly discuss activities engaged in since the previous public meeting.

Commissioner Rick Shepherd

Commissioner Harry Adams

Commissioner Gerhard Weber

Commissioner Wes White, Secretary

Commissioner Brian Stone, President

5. Adjourn to Closed Session

CLOSED SESSION

- a. CONFERENCE WITH LEGAL COUNSEL – EXISTING LITIGATION
(Government Code section 54956.9(d)(1))
Crescent City Harbor District v. Crescent Fire Protection District
Del Norte County Superior Court Case No.: CVUJ-2021-1248

6. Adjourn Closed Session

7. Report out of Closed Session



8. ADJOURNMENT

Adjournment of the Board of Harbor Commissioners will be until the next meeting scheduled for Tuesday, October 19, 2021, at 2 p.m. PDT. In accordance with AB 361, all Harbor Commission meetings will be held via Zoom Web Conferencing. Access code for public participation can be found in the meeting notice posted on the Harbor District website or on the Harbor bulletin board at 101 Citizens Dock Road.

The Crescent City Harbor District complies with the Americans with Disabilities Act. Upon request, this agenda will be made available in appropriate alternative formats to person with disabilities, as required by Section 12132 of the Americans with Disabilities Act of 1990 (42 U.S.C. §12132). Any person with a disability who requires modification in order to participate in a meeting should direct such request to (707) 464-6174 at least 48 hours before the meeting, if possible.

